

Reg. No. :

--	--	--	--	--	--	--	--	--	--	--	--	--	--	--	--	--	--	--	--

**Question Paper Code : 20515**

B.E./B.Tech. DEGREE EXAMINATIONS, NOVEMBER/DECEMBER 2023.

Third/Fourth Semester

Mechanical Engineering

CE 3491 – STRENGTH OF MATERIALS

(Common to : Industrial Engineering and Management/Mechanical Engineering  
(Sandwich)/Industrial Engineering and Safety and Fire Engineering)

(Regulations 2021)

Time : Three hours

Maximum : 100 marks

Answer ALL questions.

PART A — (10 × 2 = 20 marks)

1. What is meant by Poisson's ratio?
2. Give the relation between three moduli.
3. Define point of contraflexure.
4. Define flitched beams.
5. Compute the torsional rigidity of a 100 mm diameter, 4 m length shaft  
 $c = 80\text{kN/mm}^2$ .
6. What is meant by spring constant?
7. Write the equations in double integration method.
8. Define Moment Area theorem.
9. Define hoop stress.
10. List down the stresses acting in thin and thick cylinders.

PART B — (5 × 13 = 65 marks)

11. (a) Fig. 1 shows a steel bar is 900 mm long; its two ends are 40 mm and 30 mm in diameter and the length of each rod is 200 mm. The middle portion of the bar is 15 mm in diameter and 500 mm long. If the bar is subjected to an axial tensile load of 15 kN, find its total extension, Take  $E = 200 \text{ GN/m}^2$ .

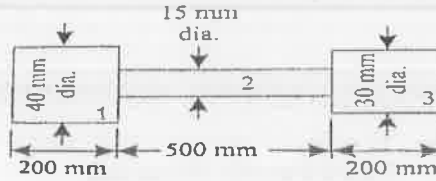

Fig. 1

Or

- (b) Fig. 2 shows a steel rod of 3 cm diameter is enclosed centrally in a hollow copper tube of external diameter 5 cm and internal diameter of 4 cm. The composite bar is then subjected to an axial pull of 45000 N. If the length of each bar is equal to 15 cm, Determine :

- (i) The stresses in the rod and tube and (7)  
 (ii) Load carried by each bar, (6)

Take  $E$  for steel =  $2.1 \times 10^5 \text{ N/mm}^2$  and for copper  $1.1 \times 10^5 \text{ N/mm}^2$ .

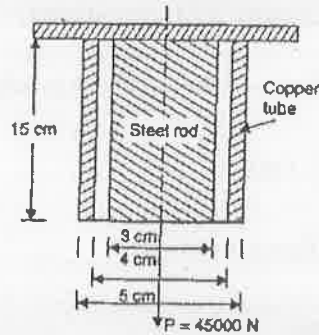

Fig. 2

12. (a) Draw the S.F and B.M. diagrams for simply supported beam loaded as shown in Figure. 3.

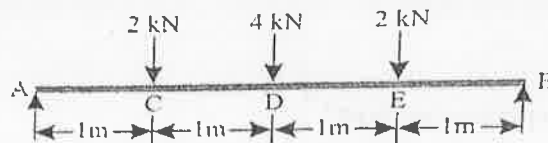

Fig. 3

Or

- (b) A steel plate of width 120 mm and of thickness 20 mm is bent into a circular arc of radius 10 m. Determine the maximum stress induced and the bending moment which will produce the maximum stress. Take  $E = 2 \times 10^5 \text{ N/mm}^2$ .

13. (a) A hollow shaft of external diameter 120 mm transmits 300 kW power at 200 r.p.m. Determine the maximum internal diameter if the maximum stress in the shaft is not to exceed 60 N/mm<sup>2</sup>.

Or

- (b) A close-coiled helical spring is to have a stiffness of 900 N/m in compression, with a maximum load of 45 N and a maximum shearing stress of 120 N/mm<sup>2</sup>. The solid length of the spring (i.e., coils touching) is 45 mm. Find

(i) the wire diameter. (5)

(ii) the mean coil radius and (5)

(iii) the number of coils (3)

Take modulus of rigidity of material of the spring =  $0.4 \times 10^5$  N/mm<sup>2</sup>.

14. (a) A simply supported steel girder of 6 m length acting as a beam carries a udl 3555 N/m run throughout its length. If  $I = 30 \times 10^{-6}$  m<sup>4</sup> and depth 270 mm, calculate The slope and deflection in the beam at a distance of 1.8 m from one end. Take  $E = 200$  GN/m<sup>2</sup>.

Or

- (b) A simply supported wooden beam 150 mm wide and 250 mm deep has a span of 4 m. Determine the load, that can be placed at its centre to cause the beam a deflection of 12 mm. Take  $E = 6 \times 10^6$  kN/m<sup>2</sup>. And find the maximum slope.

15. (a) A cylindrical thin drum 80 cm in diameter and 3 m long has a shell thickness of 1 cm. If the drum is subjected to an internal pressure of 2.5 N/mm<sup>2</sup>, determine

(i) Change in diameter

(ii) Change in length

(iii) Change in volume.

Take  $E = 2 \times 10^5$  N/mm<sup>2</sup>; poisson's ratio = 0.25.

Or

- (b) A cylindrical shell 3 meters long has 1 metre internal diameter and 15 mm metal thickness. Calculate the circumferential and longitudinal stresses induced and also changes in the dimensions of the shell, if it is subjected to an internal pressure of 15 kg/cm<sup>2</sup>. Take  $E = 2.0 \times 10^6$  kg/cm<sup>2</sup> and Poisson's ratio = 0.3.

PART C — (1 × 15 = 15 marks)

16. (a) Two brass rods and one steel rod together support a load as shown in Fig. 4. If the stresses in brass and steel are not to exceed  $60 \text{ N/mm}^2$  and  $120 \text{ N/mm}^2$ , find the safe load that can be supported. Take  $E$  for steel =  $2 \times 10^5 \text{ N/mm}^2$  and for brass =  $1 \times 10^5 \text{ N/mm}^2$ . The cross-sectional area of steel rod is  $1500 \text{ mm}^2$  and of each brass rod is  $1000 \text{ mm}^2$ .

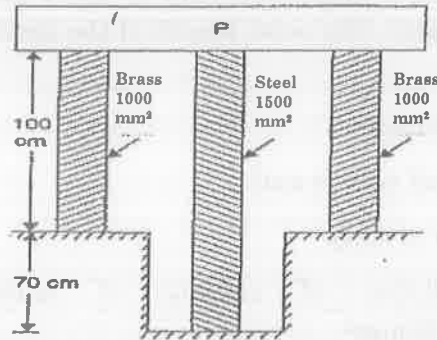

Fig. 4

Or

- (b) A steel tube of 30 mm external diameter and 20 mm internal diameter encloses a copper rod of 15 mm diameter to which it is rigidly joined at each end. If, at a temperature of  $10^\circ \text{C}$  there is no longitudinal stress, calculate the stresses in the rod and tube when the temperature is raised to  $200^\circ \text{C}$ . Take  $E$  for steel and copper as  $2.1 \times 10^5 \text{ N/mm}^2$  and  $1 \times 10^5 \text{ N/mm}^2$  respectively. The value of co-efficient of linear expansion for steel and copper is given as  $11 \times 10^{-6}$  per  $^\circ \text{C}$  and  $18 \times 10^{-6}$  per  $^\circ \text{C}$  respectively.